

MEEF

**Introducing the Specifications of the Metro
Ethernet Forum**

Introducing the Specifications of the Metro Ethernet Forum

MEF 2	Requirements and Framework for Ethernet Service Protection
MEF 3	Circuit Emulation Service Definitions, Framework and Requirements in Metro Ethernet Networks
MEF 4	Metro Ethernet Network Architecture Framework Part 1: Generic Framework
MEF 6	Metro Ethernet Services Definitions Phase I
MEF 7	EMS-NMS Information Model
MEF 8	Implementation Agreement for the Emulation of PDH Circuits over Metro Ethernet Networks
MEF 9	Abstract Test Suite for Ethernet Services at the UNI
MEF 10	Ethernet Services Attributes Phase I
MEF 11	User Network Interface (UNI) Requirements and Framework
MEF 12	Metro Ethernet Network Architecture Framework Part 2: Ethernet Services Layer
MEF 13	User Network Interface (UNI) Type 1 Implementation Agreement
MEF 14	Abstract Test Suite for Ethernet Services at the UNI
MEF 15	Requirements for Management of Metro Ethernet Phase 1 Network Elements
MEF 16	Ethernet Local Management Interface

* MEF 10 * replaced MEF 1 and MEF 5

This Presentation

- **Purpose**

- This presentation is intended as an introduction and companion to both the MEF 3 and MEF 8 Specifications
- These are the two principal specifications relating to services that carry Circuit Emulation/TM traffic across Carrier Ethernet

- **Audience**

- It is intended for Product Marketing, Engineering staff of member companies, for members of other standards bodies, Enterprise networking staff, and service providers who
 - Would like a quick overview of the specifications
 - Plan to read the specifications in detail

- **Other Documents**

- Presentations of the other specifications and an overview of all specifications is available on the MEF web site
- Other materials such as white papers and case studies are also available

MEF Specifications Overview

MEF 3	Circuit Emulation Service Definitions, Framework and Requirements in Metro Ethernet Networks
Purpose	Circuit Emulation Service “tunnels” TDM traffic through a Metro Ethernet network allowing inclusion of legacy networks within a Carrier Ethernet environment
Audience	Equipment Manufacturers supporting devices that provide Circuit Emulation over Carrier Ethernet Services. Useful for Service Providers architecting their systems.

Technical Committee Service Area

MEF 8	Implementation Agreement for the Emulation of PDH Circuits over Metro Ethernet Networks
Purpose	Gives precise instructions for implementing interoperable CES equipment that reliably transport TDM circuits across Metro Ethernet Networks while meeting the required performance of circuit emulated TDM services as defined in ITU-T and ANSI TDM standards
Audience	Equipment Manufacturers supporting devices that provide Circuit Emulation over Carrier Ethernet Services. Useful for Service Providers architecting their systems.

Technical Committee Service Area

- **Industry's first formal definition of CES standards over Ethernet**
- **A services description**
 - Types of TDM services offered over Metro Ethernet,
 - PDH and SONET/SDH
 - DS1E1, DS3/E3, OC-3/STM-1, OC-12/STM-4
- **A requirement document**
 - Comprehensive CES requirements for providing TDM services over Ethernet
 - SLA service quality parameters as specified by the ITU for TDM services
- **An implementation agreement for Ethernet**
 - Practical agreement as to how to implement the CES over Ethernet

What is Circuit Emulation Service over Carrier Ethernet?

- **Circuit Emulation Service “tunnels” TDM traffic through a Metro Ethernet network**
 - packet network “emulates” a circuit-switched network, re-creating the TDM circuit at the far end
 - invisible to TDM source and destination equipment
 - runs on a standard Ethernet Line Service (E-Line)

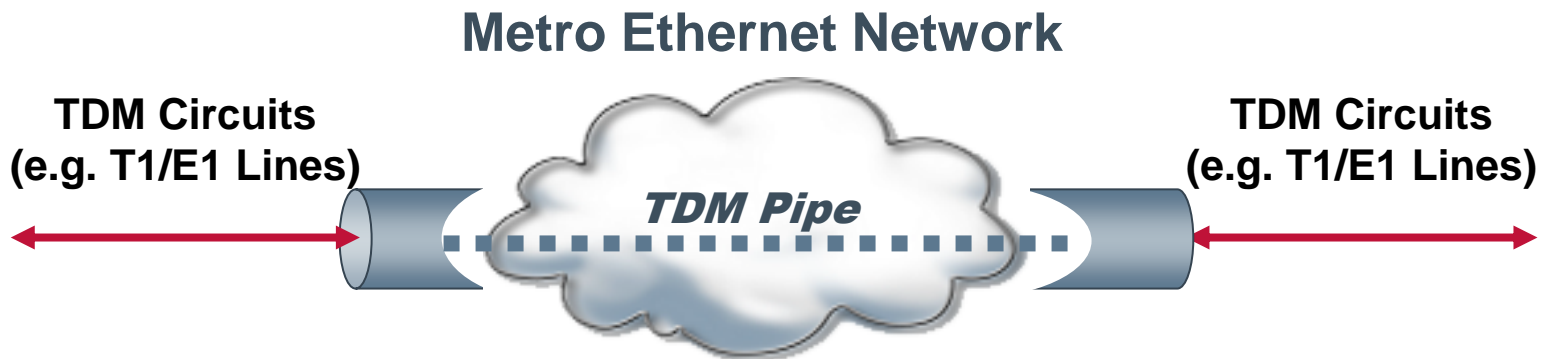

MEF 3 TDM Circuit Emulation

- Support Traditional PDH/SONET/SDH hand-offs to existing customer voice equipment
- Allow Interworking onto Ethernet EVCS across the MEN.

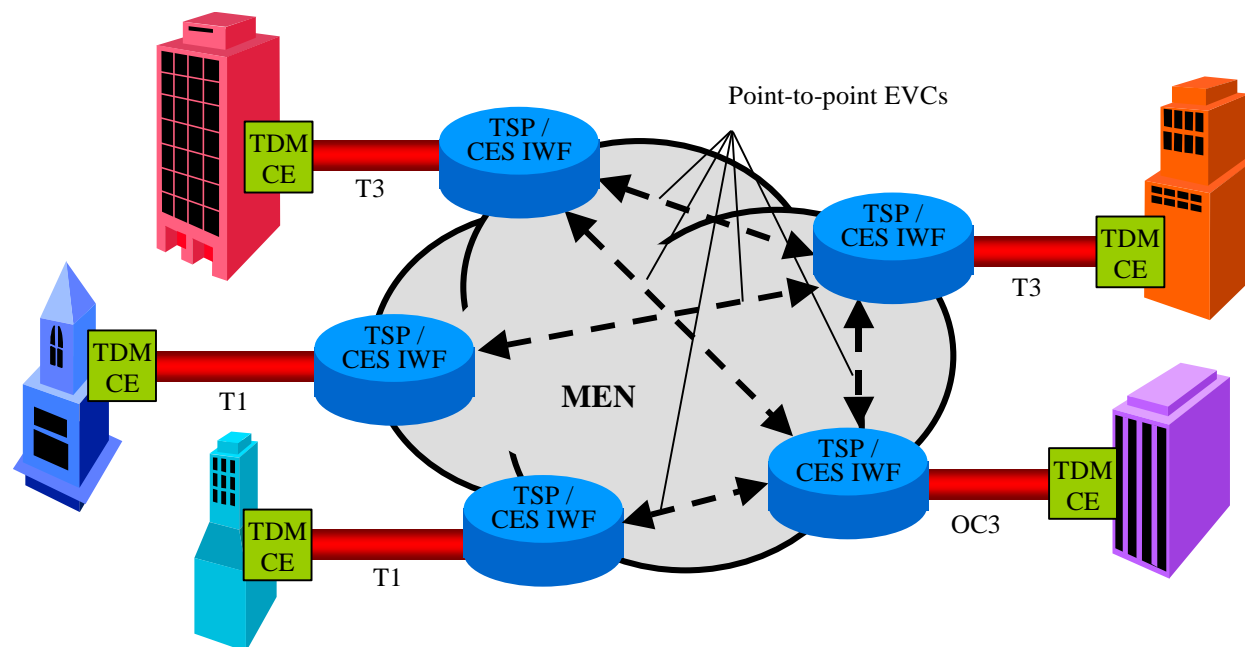

- Types:
- 1) Unstructured - all bits in must be sent across to the destination
 - 2) Structured - Requires only sending TDM payloads not the over head

Circuit Emulation Services Relationship to the Metro Ethernet Network

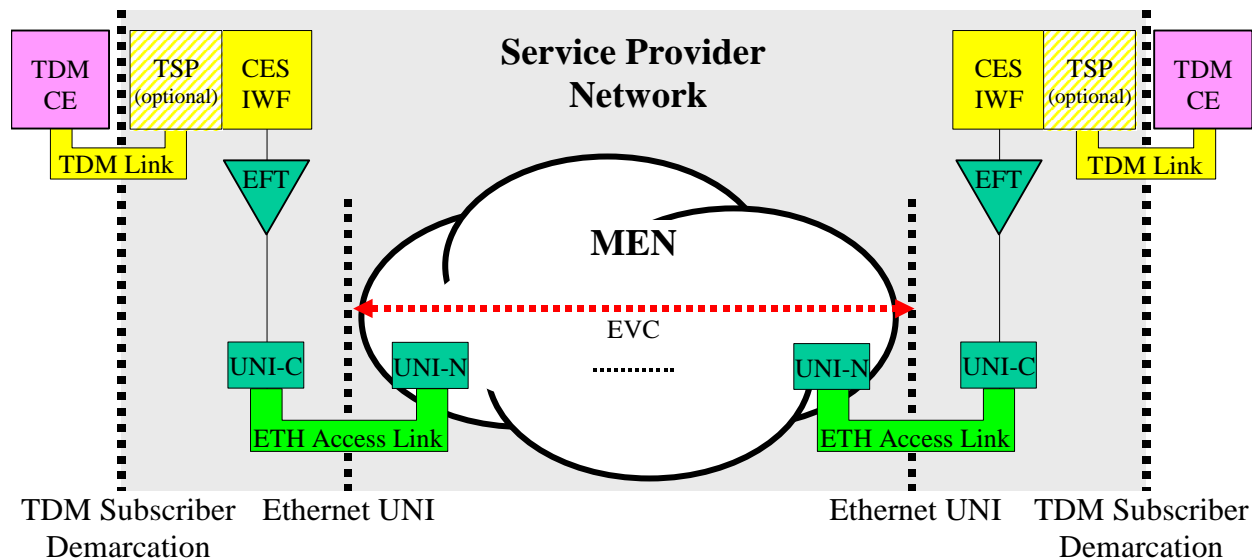

- **CES functions in relation to those specified by the MEF for the MEN**

Functions Defined

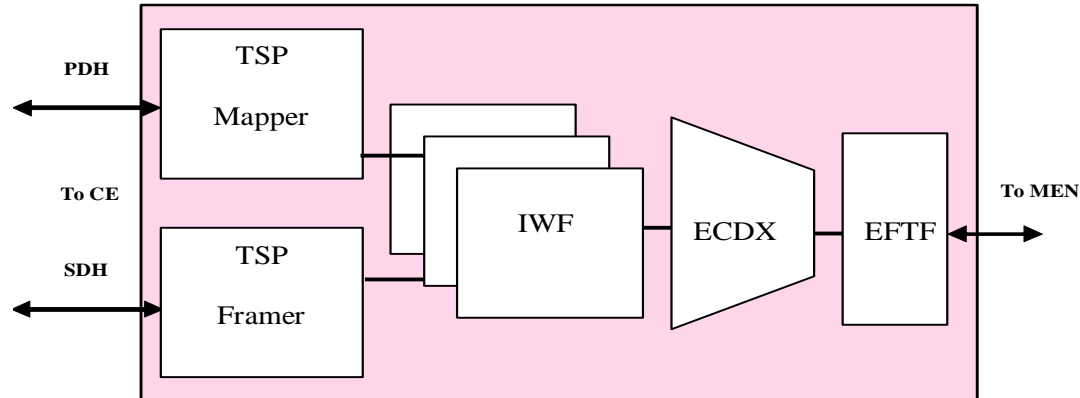

- **TSP - Optional TDM mux/demux function –prior to Ethernet interworking**
- **IWF - Interworking function of TDM to Ethernet frames**
- **ECDX - Identifier function for proper forwarding and demultiplexing**
- **EFTF –Addressing and FCS functions.**

Functions applied

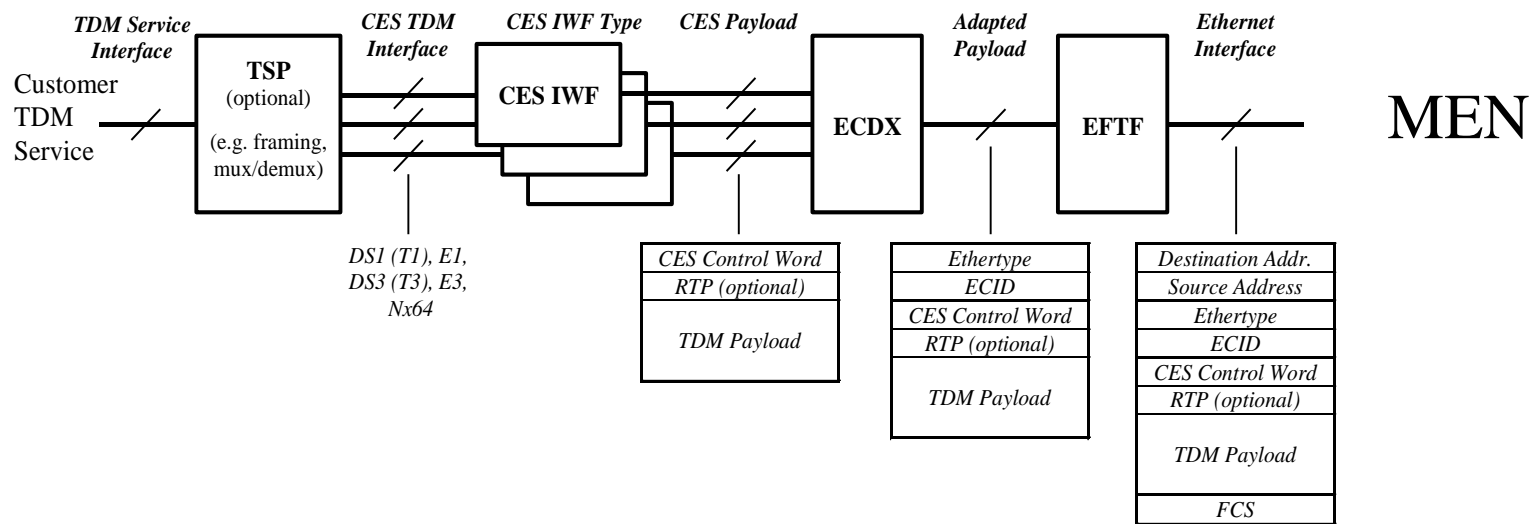

- **ECDX as shown is effectively a multiplexing function allowing multiple CES circuits to share a single EVC**

Functional Layering, and mapping onto encapsulation headers

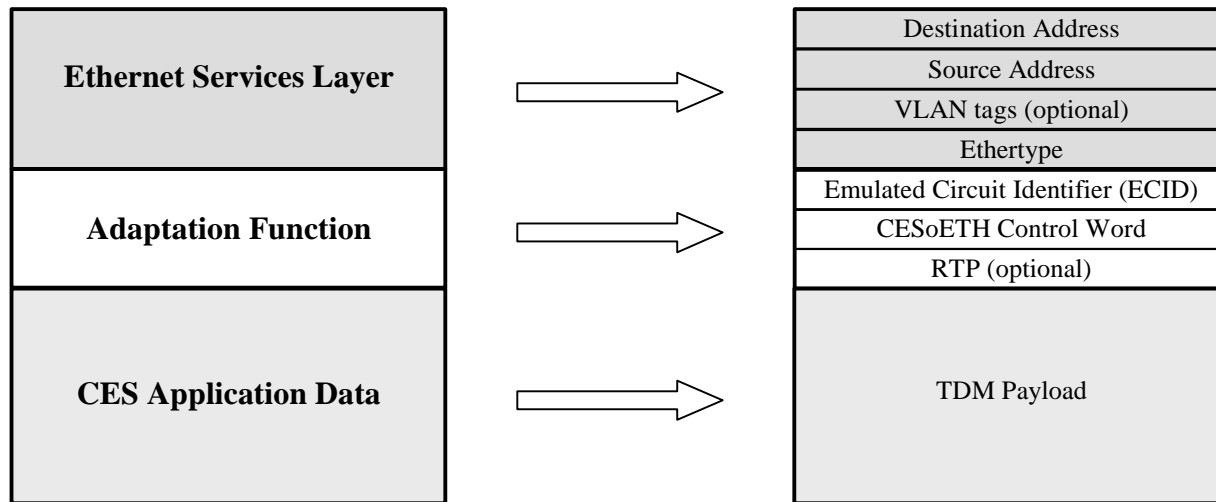

- **Treats the MEN as a “virtual wire” between two TDM networks**

MEF Service Definitions

- **TDM Line Service (T-Line):**
 - Application: Leased line replacement

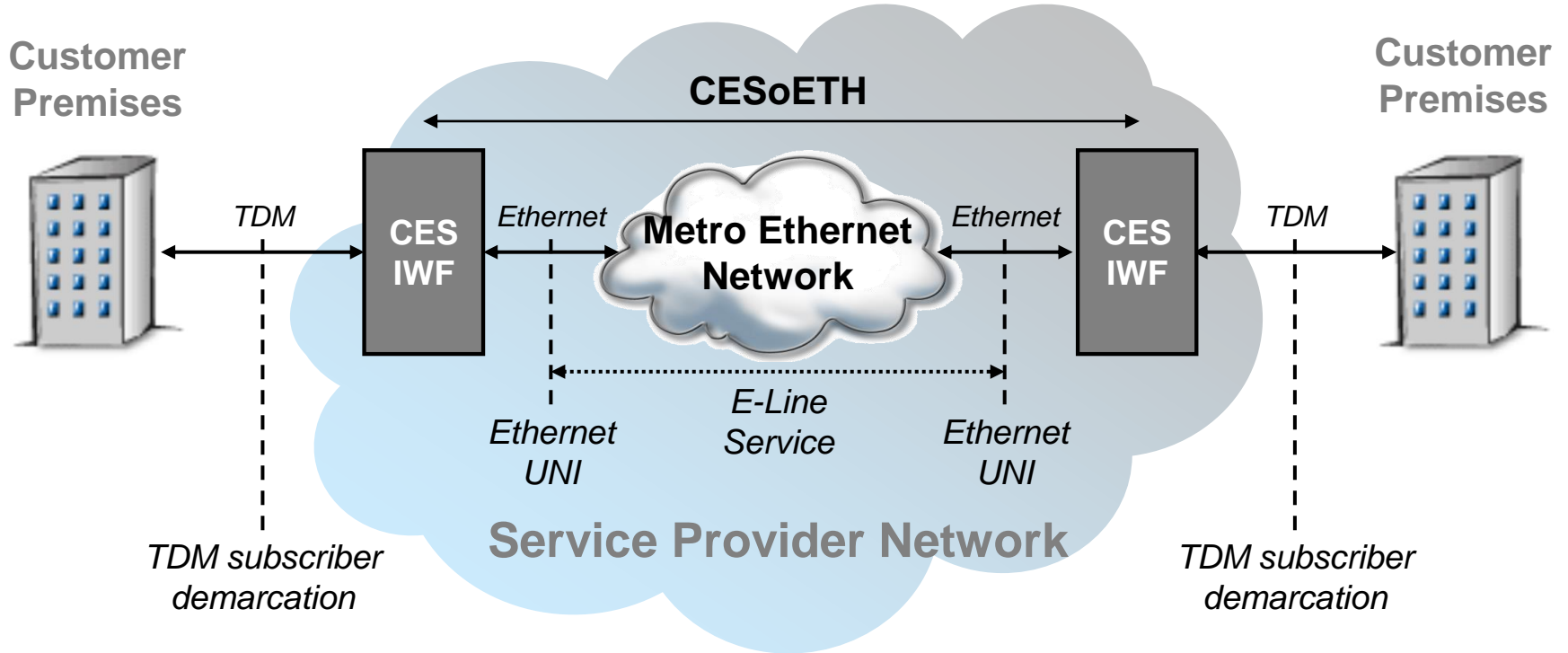

MEF Service Definitions

- **TDM Access Line Service (TALS):**
 - Application: Access to a remote network (e.g. PSTN)

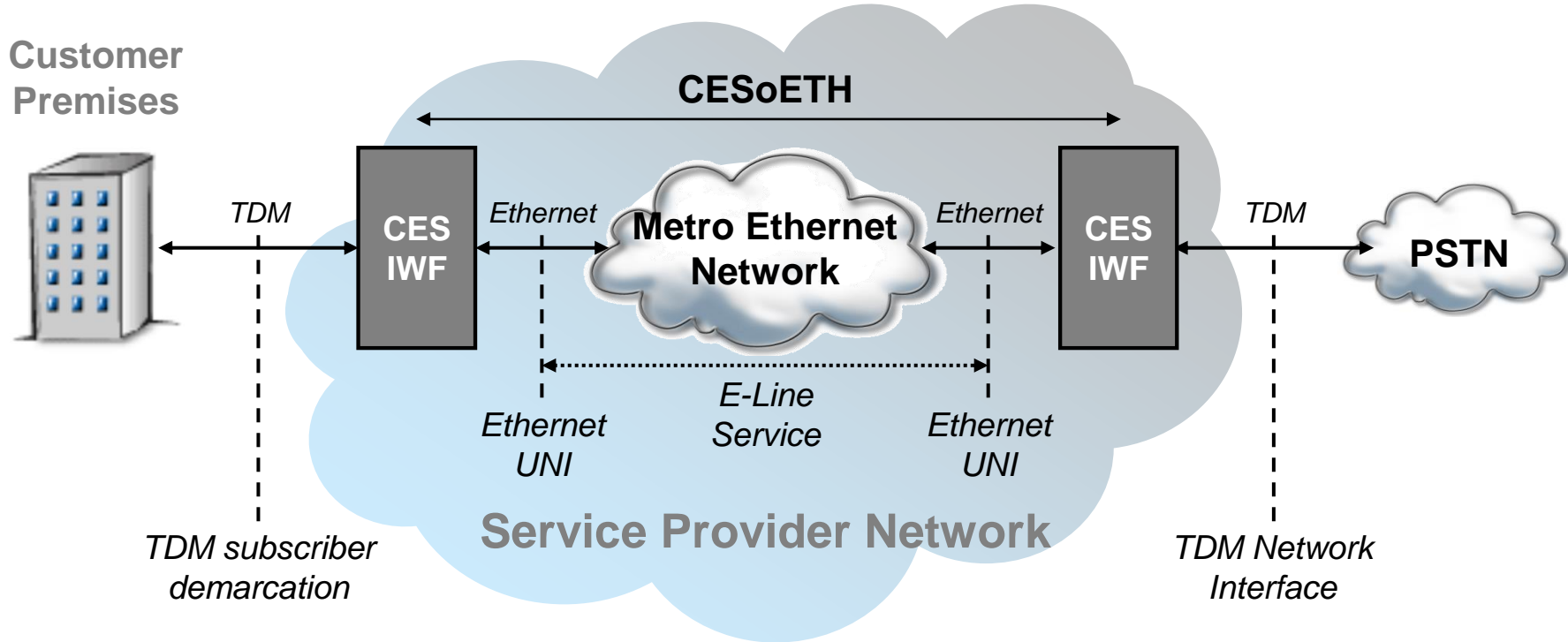

MEF Service Definitions

- **Customer-Operated CES:**
 - Application: Toll-bypass

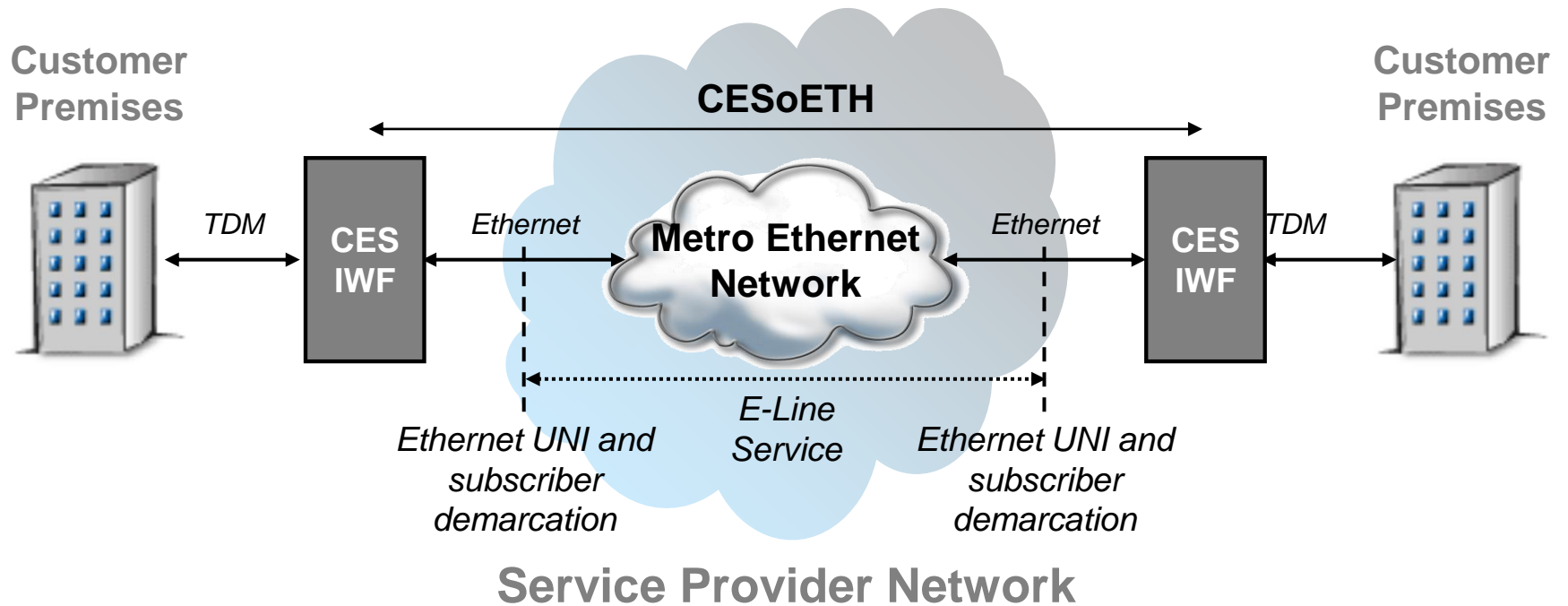

Structured Vs Unstructured CES

Structured Circuit Emulation Service



Structure-Agnostic or Unstructured Circuit Emulation Service



TDM services supported (MEF 3)

TDM Service Interface	Unstructured TDM Service	Structured TDM Service	Structured TDM Service Granularity
DS1	Yes	Yes	Nx64 kbit/s
DS3	Yes	Yes	DS1, Nx64 kbit/s
E1	Yes	Yes	Nx64 kbit/s
E3	Yes	Yes	E1, Nx64 kbit/s, DS0
OC-1	Yes	Yes	STS-1, VT-1.5, VT-2
OC-3	Yes	Yes	STS-1, VT-1.5, VT-2
OC-3c	Yes	Yes	STS-3c
STM-1	Yes	Yes	VC-11 (DS1), VC-12 (E1), VC-3 (DS3, E3, other)
STM-1c	Yes	Yes	VC-4, VC-3, VC-11, VC-12
OC-12	Yes	Yes	VT-1.5 (DS1), VT-2 (E1), STS-1 (DS3, E3, other), STS-3c
OC-12c	Yes	Yes	STS-12c
STM-4	Yes	Yes	VC-11 (DS1), VC-12 (E1), VC-3 (DS3, E3, other), VC-4
STM-4c	Yes	Yes	VC-4-4c

MEN CoS Performance Parameters

To ensure proper CES IWF operation service quality:

- **Ethernet Frame Delay should be minimized**
 - to meet MEF 5 defined parameters
- **Ethernet Frame Delay Variation**
 - MEN EVCS jitter up to 10 ms max
- **Ethernet Frame Loss**
 - ESR and SESR should meet TDM requirements
- **Network availability**
 - should meet 99.95% TDM requirement

Specifies Interoperability requirements for:

- **Connectivity**
- **Timing**
- **Signaling**
- **MEN performance criteria**
- **MEN services OAM**

Emulated Circuit Identifier



ECID

- – identifies the emulated circuit being carried.
- Separates the identification of the emulated circuit from the Ethernet layer,
 - allowing the MEN operator to multiplex several emulated circuits across a single EVC where required.
- This is added by the ECDX.

CESoETH control word

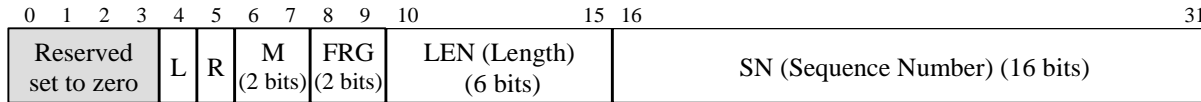

- **Provides sequencing and signaling of defects**
 - such as AIS of the TDM circuit, or packet loss detected in the MEN.
- **This is added by the CES IWF.**

Standards for Synchronization

E1 standards (2.048 Mbps)

- Traffic interface (G.823, Table 2)
 - 18 μ s over 1000s

T1 standards (1.544 Mbps)

- Traffic interface (T1.403, section 6.3.1.2)
 - 8.4 μ s over 900s
 - 18 μ s over 24 hours

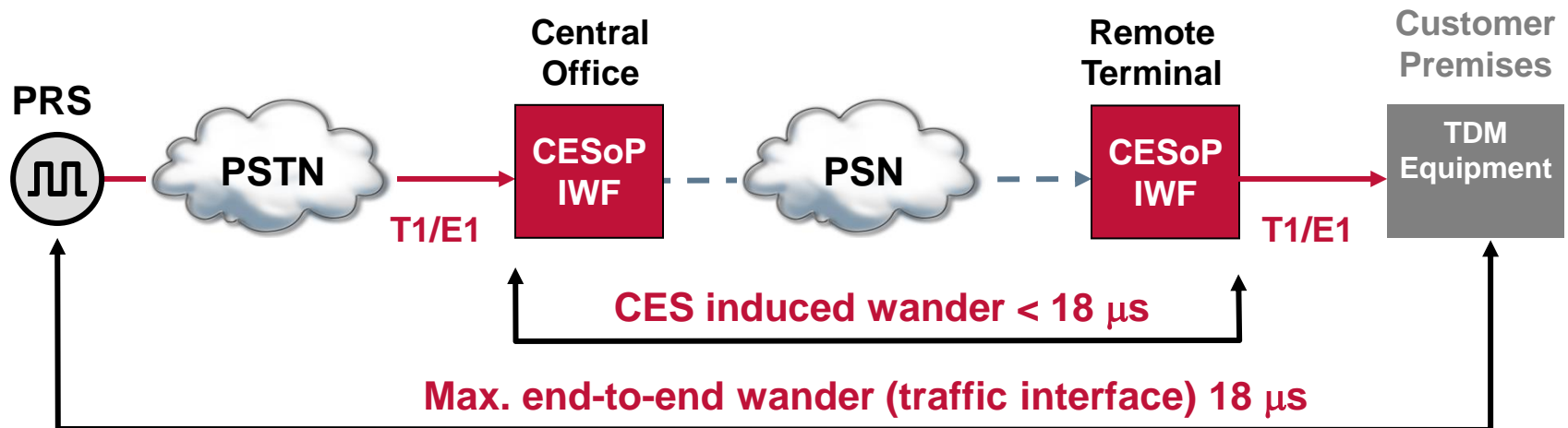

Timing

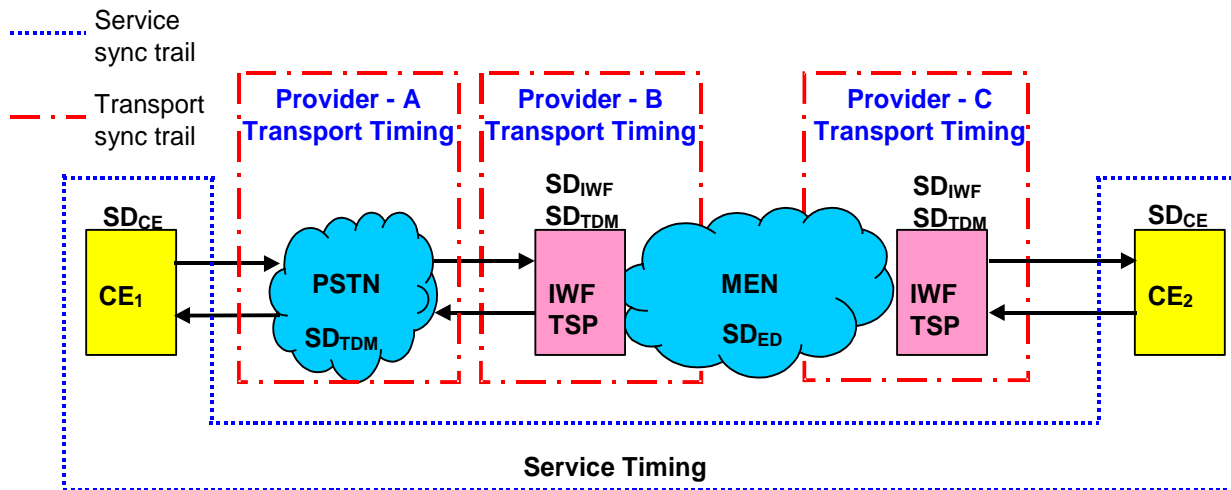

- **Synchronous services require timing be provided**
 - Line, through, external or internal timing mode options
- **Applies to structure aware only**
- **Synchronization.**
 - the clock used to play out the data at the TDM-bound IWF must be the same frequency as the clock used to input the data at the MEN-bound IWF,
 - otherwise frame slips will occur over time

Timing options

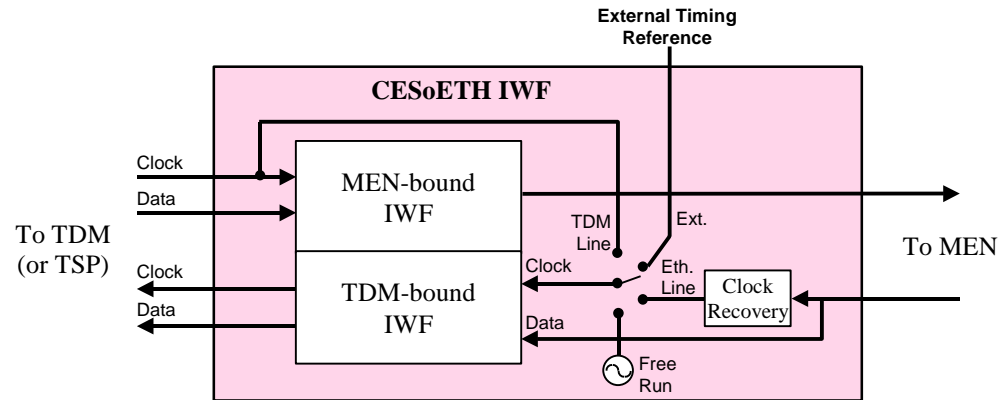

- **TDM line timing**
 - use the clock from the incoming TDM line
- **External timing**
 - use an external reference clock source
- **Free run timing**
 - use a free-running oscillator
- **Ethernet line timing**
 - recovering the clock from the Ethernet interface

- **Structure Aware CESoETH must provide signaling**
 - CE Common Channel Signaling (CCS)
 - Can be carried within the emulated service data
 - CE Common Channel Signaling (CAS)
 - Must be handled separately for Nx64 service

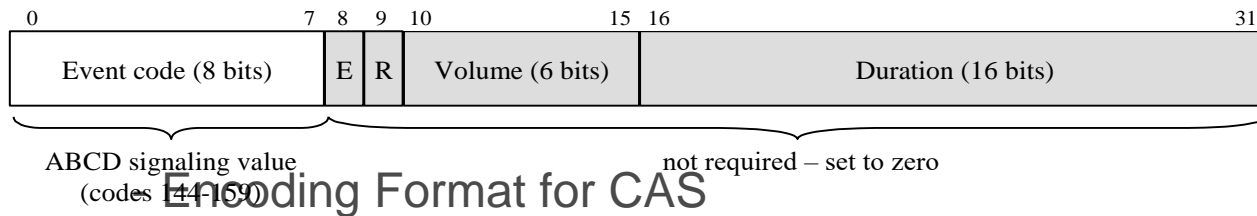

- Note must have a separate Control Word from the Data, but can share same ECID

Performance Monitoring

- **Facility Data Link**
 - May monitor but not change DS1 Extended Super Frame message data
- **Errored Data**
 - CESoETH should be capable of monitoring Frame Error ratio

MEN Service & SLA Requirements

- **MEN service quality assurance is critical to maintain consistent quality of the carried TDM service**
- **SLA service quality parameters should support to those specified by the ITU for TDM services**
 - Nx64 Services require CAS Signaling in MEN
 - SDH/SONET requires pointer adjustments in MEN
- **Specified MEN Quality Parameters:**
 - Frame Delay: <25ms
 - Jitter (Delay Variation): <10ms
 - Frame Loss/Errors Ratio (FER)
 - For SONET/SDH:
 - Errored Seconds (ES)
 - Severely Errored Sec (SES)
 - Background block SES (BFER)

Path	Rate pps	CES FER	CES BFER	CES SESFER
VC-11	2000	4.00E-07	2.00E-06	4.00E-05
	8000	1.00E-07	2.00E-06	4.00E-05
VC-12	2000	4.00E-07	2.00E-06	4.00E-05
	8000	1.00E-07	2.00E-06	4.00E-05
VC-3	8000	1.25E-07	2.00E-06	4.00E-05
	24000	4.17E-08	2.00E-06	4.00E-05
VC-4	24000	1.33E-07	2.00E-06	4.00E-05
	14400	2.22E-07	2.00E-06	4.00E-05
VC-4-4c	72000	4.44E-08	1.00E-06	4.00E-05

Frame Delay Defined

- The time required to transmit a service frame from source to destination across the MEN.

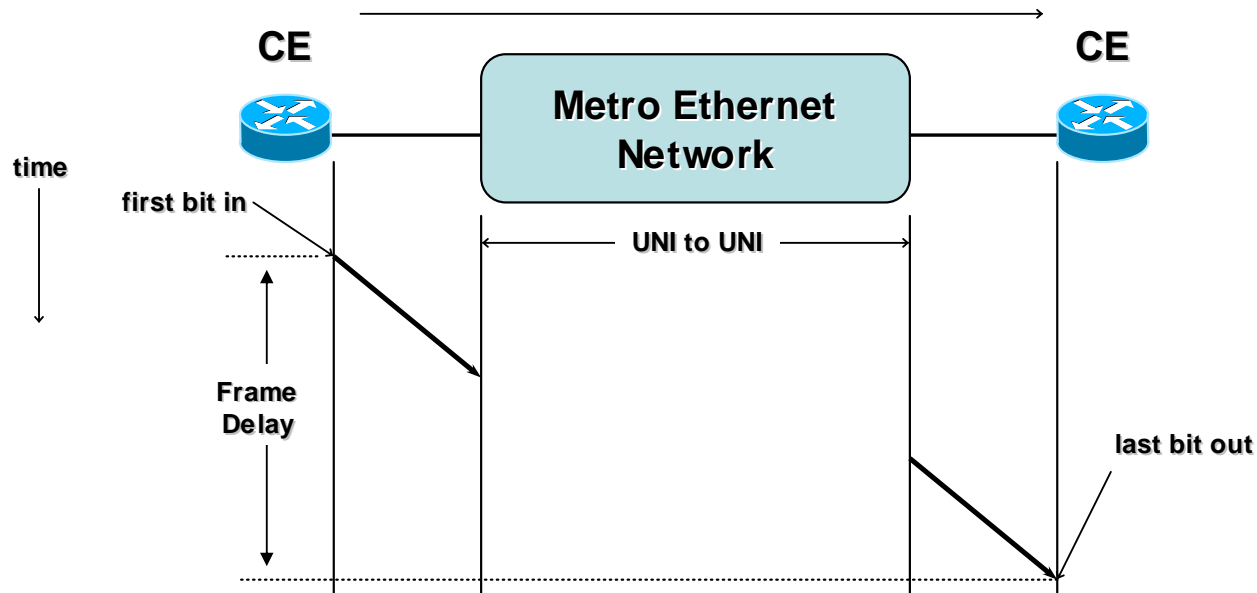

Measured from 1st bit in to last bit out

Frame Delay Variation Defined

- The difference in delay of two service frames.

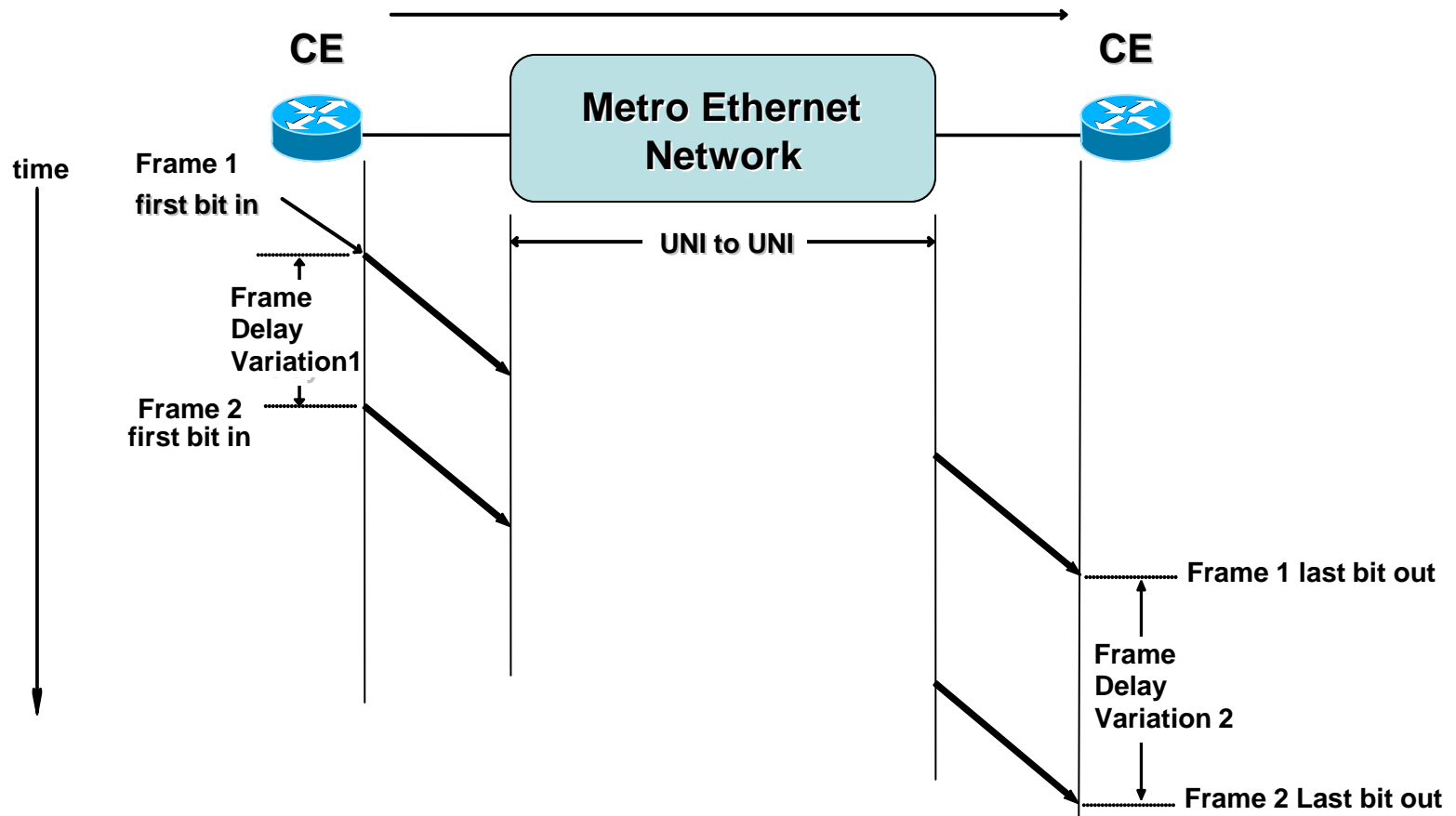

Frame Loss Defined

- **Frame loss is a measure of the number of lost service frames inside the MEN.**
 - Frame loss ratio is $\% = \# \text{ frames lost} / \# \text{ frames sent}$

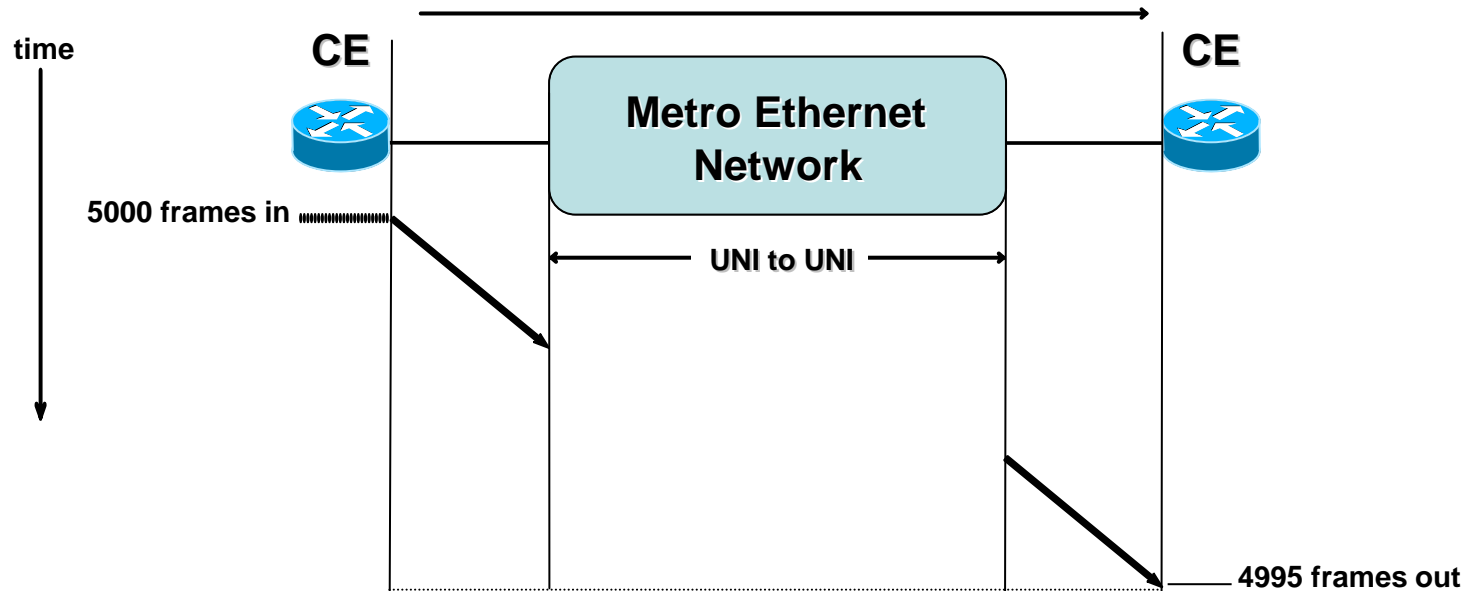

5 frames lost/or received as errored
0.1% Frame Loss Ratio (5/5000)

MEN Frame Loss Errors – PDH Limits

- PDH ES

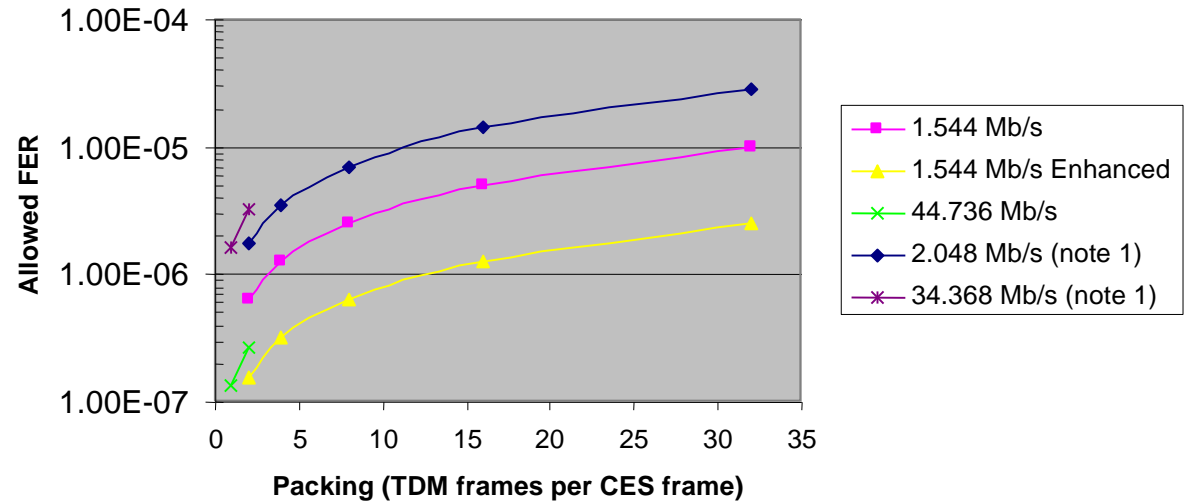

- PDH SES

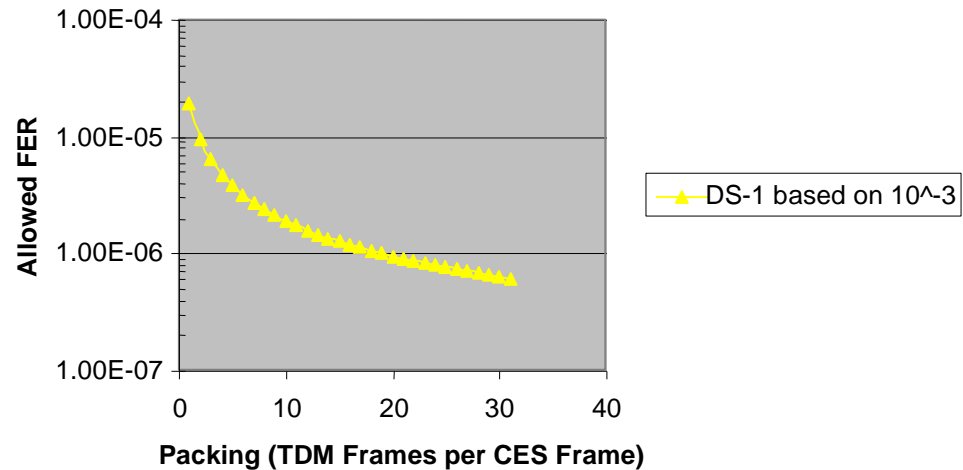

Other MEN Parameters

- **Emulated Circuit Availability**
99.95%
- **Emulated Circuit Restoral**
< 50 ms
- **Suggested MEN Bandwidth increments**
 - 100 kbps

- **Alarms**
 - Misconnection alarm (section 6.6.1)
 - Loss of Frames alarm (section 6.6.2)
 - Late Frames alarm (section 6.6.3)
 - Malformed Frames alarm (section 6.6.4)
 - Jitter buffer overrun alarm (section 6.6.5)

Management – Alarms

- **Misconnection Alarms – MEN defects:**
 - Stray Frames Must be discarded
 - CES IWF must check the Ethernet Source address field
 - Should report an alarm
 - if stray frames persists above set threshold (Default 2.5 seconds)
 - Alarm should be cleared
 - if no stray frames received for a configurable period of time (Default 10 seconds)
 - Mechanism for detection of lost frames Must Not be affected by reception of stray frames

Management – Alarm Statistics Counters

- **MEN bound**
 - Frames transmitted
 - Payload octets transmitted
- **TDM bound**
 - Frames received
 - Payload octets received
 - Lost frames detected
 - Out-of Sequence frames
 - Transitions to the LOFS (Loss of frame state)
 - Malformed frames received
 - Jitter buffer overruns
 - Jitter buffer underruns

- **ITU-T: Recommendation Y.1413**
 - Very similar to MEF8, but for MPLS networks rather than Metro Ethernet
 - Payload and encapsulation formats are identical
 - Equipment supporting Y.1413 should also be capable of supporting MEF8

Similar work in other bodies

- **IETF: draft-ietf-pwe3-satop-01.txt, draft-ietf-pwe3-cesopsn-02.txt, draft-ietf-pwe3-tdmoip-03.txt**
 - Very similar to MEF8, but for IP and MPLS networks rather than Metro Ethernet
 - As with Y.1413, payload and encapsulation formats are identical
 - Equipment supporting Y.1413 should also be capable of supporting these IETF drafts

For Full Details ...

... visit www.metroethernetforum.org
to access the full specification

